



TEST RESULTS

4695 **FIBERGLASS** **PROTECTIVE** **COATING**

- Product Literature
- NEETRAC TEST – “Durability of Coating.”
- NEETRAC TEST – “Dielectric Strength of Coating.”
- Product SDS



RAINBOW TECHNOLOGY CORPORATION

261 Cahaba Valley Parkway

Pelham, AL 35124-1146

FAX: 1-800-521-6896

www.rainbowtech.net

1-800-637-6047

PRODUCT:

FIBERGLASS PROTECTIVE COATING

THE BASICS:

- For use as a general purpose acrylic coating, suitable for most surfaces where maximum indoor/outdoor durability is desired.
- This clear acrylic coating protects ladders and other assemblies against decaying, cracking, chipping, fading and flaking caused by the weather. It can be used on all wooden and fiberglass products.
- This coating can be used on hotsticks, material handling booms, upper aerial lift and digger derrick booms and temporary change out equipment.
- This fast-drying aerosol formula requires no brushing.
- National Electric Energy Testing Research and Application Center (NEETRAC) tested for durability on fiberglass products.
- NEETRAC tested dielectrically safe.
- Protects against ultra-violet radiation.

APPLICATIONS:

Use FIBERGLASS PROTECTIVE COATING on wood and fiberglass surfaces including:

- Ladders
- All types of Disconnect Sticks
- Material Handling Booms
- Digger Derrick Booms
- Temporary Change Out Equipment
- Fiberglass Street Light Poles



FEATURES	HOW YOU BENEFIT
Protects wooden and fiberglass surfaces from weather damage	Extends equipment life
NEETRAC tested	Assured product quality
Aerosol delivery	Ease of application - no brushing needed

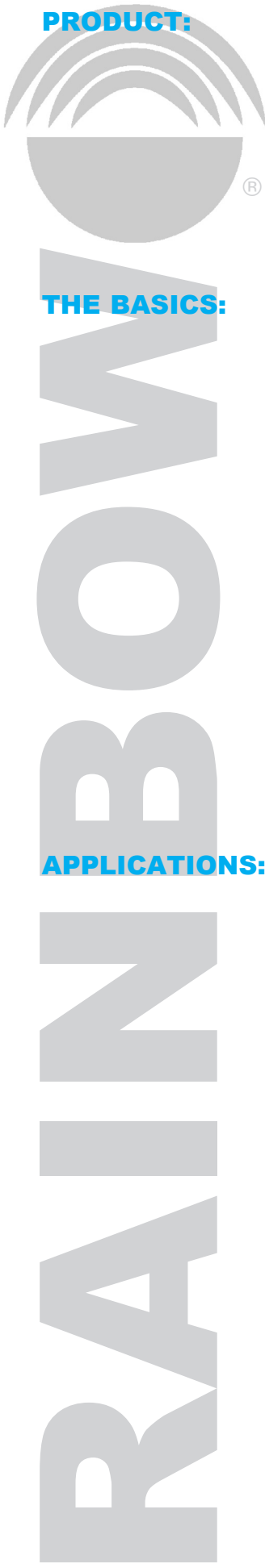

TECHNICAL HIGHLIGHTS:

Test procedures - ASTM F-711 "Specification for Fiberglass Reinforced Plastic (FRP) Rod and Tube Used in Live Line Tools" and IEEE SED 978-1984 "Guide for In-Service Maintenance and Electrical Testing of Live-Line Tools", "coating provides a dielectric finish equal to or better than the manufacturer's surface when properly cleaned." Test report available upon request.
Von DC Hi-Pot Dielectric test conducted at NEETRAC Test Report is available upon request.

®

RELATED PRODUCTS:

Rainbow Technology offers a comprehensive line of products to the utility and telecommunications industries. Users of FIBERGLASS PROTECTIVE COATING often find these other Rainbow products helpful too.

- "Knuckles" Hand & Tool Cleaning Towels (79315, 79316)
- CP Wipes (4215)
- Powersolv Cable Cleaner (4214, 42142, 42143, 4214-1, 4214-5, 4214-55)
- HD Cleaner Electrical Grade (87000)
- Clean & Lube (4410)
- Corrosion Stop (86000)
- Cold Galvanize (86010)
- Stormy® All Weather Corrosion Protector (4401)
- PIC Restoration Spray (4064)
- Silicone Spray (85000)

MATERIAL SAFETY DATA SHEET:

This product is only for sale to and use by service personnel. SDS available on request.

PACKAGING:

PRODUCT NUMBER	CONTAINER SIZE	UNITS/CASE	CASE WEIGHT	CASE SIZE
4695	11.7 oz Aerosol	12	13 lbs	8" L x 8 1/2" W x 11" H

ANSWERS TO YOUR QUESTIONS:

Do you have a question about any Rainbow Technology product? Because we've been supplying the utility and telecommunications industries since 1971, our technical support team has the expertise to provide answers and solutions.
Just call us at **1-800-637-6047**.

RAINBOW TECHNOLOGY
Specialists in Utility Chemicals

Correspondence:
PO Box 26445
Birmingham, AL 35260-0445

Shipping:
261 Cahaba Valley Parkway
Pelham, AL 35124-1146

Phone: (800) 637-6047 or (205) 733-0333
Fax: (800) 521-6896 or (205) 733-8930
E-mail: sales@rainbowtech.net
Website: www.rainbowtech.net

Distributed in Australia by

ADAPT AUSTRALIA
11-19 Global Drive
Westmeadows, Vic, Australia, 3049.
PH: +61 3 9330 0666
Fax: +61 3 9330 0777

Distributed in New Zealand by

ADAPT NEW ZEALAND
25 Hampden Street Picton 7220
Marlborough, New Zealand.
PH: +64 2150 7831



Rainbow Technology
FRP Spray Coating Durability Evaluation
NEETRAC Project No. 97-160

February 1998

Requested By: Larry J. Steeley Jr.
Rainbow Technology

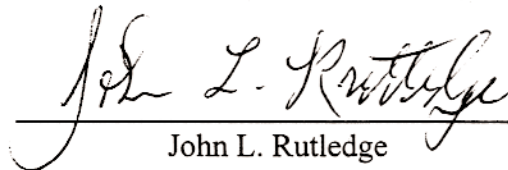
Evaluated by: 
John L. Rutledge

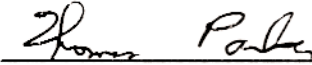
Review By: 
Thomas Parker

Rainbow Technology
FRP Spray Coating Durability Evaluation
Project No. 97-160

Scope:

NEETRAC was requested to evaluate the durability of Rainbow Wooden and Fiberglass Ladder Protective Spray Coating when applied to Fiberglass-Reinforced Plastic (FRP) Live Line Tools. Research has shown that moisture penetration under the surface and within the hot stick leads to adverse dielectric properties and a loss of adhesion of the surface finish. In addition, if water that does collect on the surface sheen over rather than bead up, adverse dielectric behavior and even flash over can occur during electrical operations. The durability of a coating used on FRP tools may be evaluated by its ability to remain adhered to the substrate and retain acceptable dielectric properties under conditions of high humidity. Test procedures taken in part from ASTM F-711 "Specification for Fiberglass-Reinforced Plastic (FRP) Rod and Tube Used in Live Line Tools" and IEEE Std 978-1984 "Guide for In-Service Maintenance and Electrical Testing of Live-Line tools" will be used for this evaluation.

The spray coating was supplied by Rainbow Technology and NEETRAC procured representative samples of FRP Live Line Tools from A. B. Chance Company, Kearney Hi-Line Tool Corporation, Hastings Fiber Glass Products Inc., and Jameson Corporation. After proper sample preparation, NEETRAC applied the spray coating to the FRP test samples and evaluated the coating's durability based on adherence and dielectric performance.

Summary:

The Rainbow Wooden and Fiberglass Ladder Protective Spray Coating proved to be a durable coating when applied to the FRP substrates. The coated test specimens showed no visual signs of loss of adhesion and retained acceptable dielectric properties following the Electrical Design Test (Procedure I) and Wet Dielectric Test (Procedure II). (See Table 2 & Table 3)

Sample Preparation:

FRP tubes from each manufacturer (See Table 1 below) were procured for this test program. Test and control FRP samples, each 1-1/4 inch OD, were cut into one foot lengths. The control samples were evaluated as received. The test samples were lightly sanded to remove the existing outer surface and establish a profile to which the Rainbow Spray coating was applied. Several thin coats, with appropriate drying time between coats, were applied to the FRP test substrates until full coverage was achieved. The coated test samples were then allowed two weeks to cure prior to testing.

Table 1:

Manufacturer	Electrical Certification of FRP Tool
Jameson Corporation	Fiberglass pole was tested per OSHA specifications prior to leaving the factory. Tested at 100 kV per ft. for 5 minutes per OSHA Subpart V Section 1926.951 (d)
Hastings Fiber Glass Products Inc.	Fiberglass product Model Number 464. The components of this product were tested per OSHA specification prior to leaving the factory
A. B. Chance	Chance epoxiglass pole is certified to meet OSHA Subpart V Section 1926.951 (D), ASTM F711, and IEC 855
Kearney Hi-Line Tool	Product tested to withstand 100kV per foot for 5 minutes. Tested to OSHA and ASTM F-711-89

Procedure (I)**Electrical Design Test:**

Test and control FRP tube samples were taken from New Hot Sticks. Test setups are shown in Figure 1 & Figure 2. The samples were subjected to accelerated weathering and electrically tested per procedures outlined in the ASTM F-711 as follows:

Conditioning Prior to Electrical Tests

Prior to the first or initial electrical test, the samples were wiped clean with a damp rag. After the initial cleaning, the samples remained in the ambient atmosphere of the test premises for at least 24 hours.

Initial Electrical Tests (I_1)

The samples were properly positioned in the electrical test setup as shown in Figure 1 & 2. A voltage of 100 kV rms at 60 Hz was applied between the electrodes at a maximum voltage rise of 3000 V/s. The recorded current (I_1) is the maximum dielectric current measured between the electrodes for 1 minute.

Moisture Conditioning

The samples were placed in the Thermotron Weathering Chamber and underwent the following conditioning:

Time	168 hours
Temperature	$23 \pm 2^\circ\text{C}$
Relative humidity	93 % , or greater

Final Electrical Tests (I_2)

After moisture conditioning and a light wiping with a dry cloth, the current (I_2) was measured under the same conditions as was I_1 .

Results:

Both the Test FRP Samples (coated) and the Control FRP Samples passed the Electrical Design Test. The acceptance criteria for current measurements is that the difference between I_1 and I_2 shall be less than 20uA. See Table 2.

Figure 1: Typical A-C Test Set Up

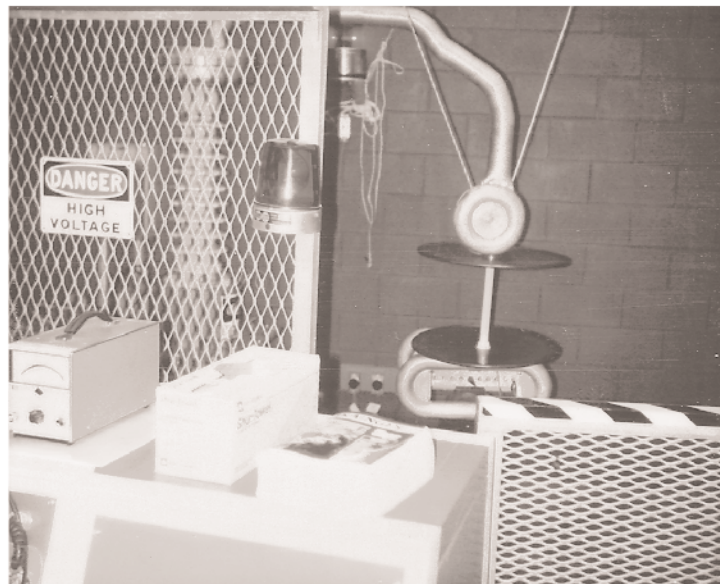
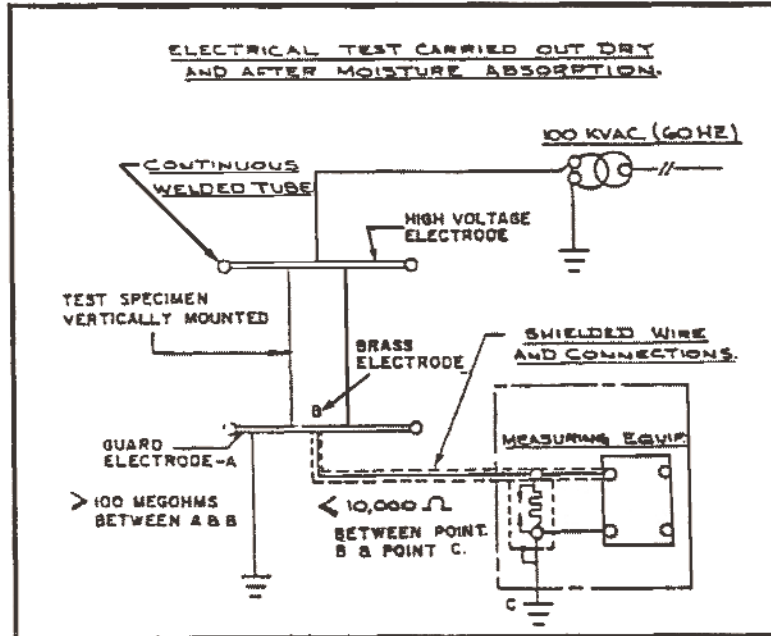

Figure 2: Actual Electrical Test Set-Up

Table 2:

Performance Summary FRP Samples Electrical Design Test					
		ASTM F-711 Electrical Tests (Mean Leakage Current over 1 ft. FRP Tube Sections)			
Manuf.	FRP Tube Sample (1 ft long)	Initial Electrical (I₁)	Final Electrical (I₂)	Δ Elec.	* Pass/Fail
Jameson (Test)	1.25 in. OD Dark Yellow Spiral Wrapped Foam Filled Tube	4.1uA	4.3uA	0.2 uA	Pass
Jameson (Control)	1.25 in. OD Dark Yellow Spiral Wrapped Foam Filled Tube	4.2uA	4.5uA	0.3ua	Pass
Hastings (Test)	1.25 in. OD Light Yellow Foam Filled Tube	7.05uA	8.04uA	0.99 uA	Pass
Hastings (Control)	1.25 in. OD Light Yellow Foam Filled Tube	7.10uA	8.07uA	0.97 uA	Pass
Chance (Test)	1.25 in. OD Deep Orange Foam Filled Tube (cat. # XT403-0315)	6.88uA	8.13uA	1.25uA	Pass
Chance (Control)	1.25 in. OD Deep Orange Foam Filled Tube (cat. # XT403-0315)	7.10uA	6.68uA	0.42uA	Pass
Kearney (Test)	1.25 in. OD Light Yellow Hollow Tube	6.73uA	7.56uA	0.83 uA	Pass
Kearney (Control)	1.25 in. OD Light Yellow Hollow Tube	6.65uA	7.58uA	0.93 uA	Pass

* Acceptance criteria for current measurements - The difference between I₁ and I₂ shall be less than 20 uA

Procedure (II)

Wet Dielectric Test:

Test and control FRP tube samples were taken from Used Hot Sticks. Two test samples and one control sample from each manufacturer were evaluated. A typical test setup is shown in Figures 1 & 2. This procedure differs slightly from the previous test procedure as follows:

Conditioning Prior to electrical Tests

Prior to the only electrical test (I_1), the samples were wiped clean with a damp rag.

After the initial cleaning, the samples remained in the ambient atmosphere of the test premises for at least 24 hours.

Initial Electrical Tests (I_1)

The samples were properly positioned in the electrical test setup as shown in Figure 1, & 2. The samples were then sprayed with a water mist until saturation which is achieved when the water just begins to run or drip off. The voltage potential was applied to the specimens immediately after wetting. The voltage was increase gradually (10kV ac per second) to 80 kV ac and maintained for one minute. The maximum leakage current in the ground return meter was recorded. A leakage in excess of 80 microamps signifies a failure.

(See Table 3)

Results:

The Test FRP samples, used Hot Sticks that had been re-surfaced with the Rainbow Spray Coating, passed the Wet Dielectric Tests. All of the control FRP samples, which were also taken from similar used Hot Sticks but had not been re-surfaced, failed the Wet Dielectric Tests. See Table 3.

Conclusions:

FRP tube samples, coated with the Rainbow Wooden and Fiberglass Ladder protective Coating, passed the electrical design test and the wet dielectric test as outlined. Therefore, this coating proved to be a durable surface finish for these FRP substrates when properly applied.

Table 3:

Performance Summary FRP Samples Wet Dielectric Test			
Manuf.	FRP Tube Sample (1 ft long)	Leakage Current @ 80 kV ac	* Pass/Fail
Jameson (Test-1)	1.25 in. OD Dark Yellow Spiral Wrapped Foam Filled Tube	7 uA	Pass
Jameson (Test-2)	1.25 in. OD Dark Yellow Spiral Wrapped Foam Filled Tube	7 uA	Pass
Jameson (Control)	1.25 in. OD Dark Yellow Spiral Wrapped Foam Filled Tube	Flash	Fail
Hastings (Test-1)	1.25 in. OD Light Yellow Foam Filled Tube	7 uA	Pass
Hastings (Test-2)	1.25 in. OD Light Yellow Foam Filled Tube	10 uA	Pass
Hastings (Control)	1.25 in. OD Light Yellow Foam Filled Tube	Flash	Fail
Chance (Test - 1)	1.25 in. OD Deep Orange Foam Filled Tube (cat. # XT403-0315)	6 uA	Pass
Chance (Test - 2)	1.25 in. OD Deep Orange Foam Filled Tube (cat. # XT403-0315)	6 uA	Pass
Chance (Control)	1.25 in. OD Deep Orange Foam Filled Tube (cat. # XT403-0315)	Flash	Fail
Kearney (Test - 1)	1.25 in. OD Light Yellow Foam Filled Tube	6.5 uA	Pass
Kearney (Test - 2)	1.25 in. OD Light Yellow Foam Filled Tube	6.5 uA	Pass
Kearney (Control)	1.25 in. OD Light Yellow Foam Filled Tube	Flashed	Fail

* A leakage current in excess of 80 microamps or a flash over signifies a failure to the FRP sample.

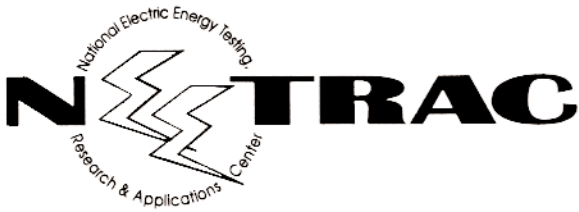

A Center of Georgia Tech
62 Lake Mirror Road
Building 3
Forest Park, GA 30050

John L. Rutledge
Phone: 404-675-1872
Fax: 404-675-1820

Date: February 5, 1997

Ref: Project Report (97-030)
Fiberglass Rod Coating Evaluation (Dielectric Test)

To: Mr. Larry Joe Steeley, Jr.
Rainbow Technology
261 Cahaba Valley Parkway
Pelham, AL 35124-1146
1-800-637-6047/205-733-0333
FAX: 1-800-521-6896/205-733-8930

The evaluation of your spray coating, Rainbow Wooden and Fiberglass Ladder Protective Coating, for dielectric characteristics is complete. The test procedure is described below:

Fiberglass substrate

- Hastings foam filled 1 1/2 inch diameter fiberglass hotstick.

Test sample (3 ft. section fiberglass rod)

- Sand and clean surface of fiberglass substrate.
- Apply several thin coats of the spray coating, allowing ample time between applications for proper adhesion.
- Allow the coating to dry thoroughly in a clean environment.

Control sample (3 ft. section fiberglass rod)

- Clean the original fiberglass rod surface according to the manufacturer's recommendations.
 - Hastings All Purpose Cleaner cat. #10-168
 - Hastings Hot Stick Boom & Bucket Wax cat. #10-091

Dry & Wet Dielectric Tests on 1 ft. sections (See Figure 1: Test Set-Up)

- Procedure patterned after Von DC Hi-Pot Test used by Georgia Power Company.
 - Suspend the stick in a horizontal position
 - Attach the test leads to springs placed at one foot intervals along the stick.
 - Spray the test segment with distilled water (Wet Test only)
 - Apply potential to test segment and increase the voltage gradually (10 kV DC per second) to 80kV DC and maintain for one minute.
 - Read the maximum leakage current in the ground return meter.
 - A leakage in excess of 80 microamperes DC (Wet Test) signifies a failure.

Figure 1: Test Set-Up

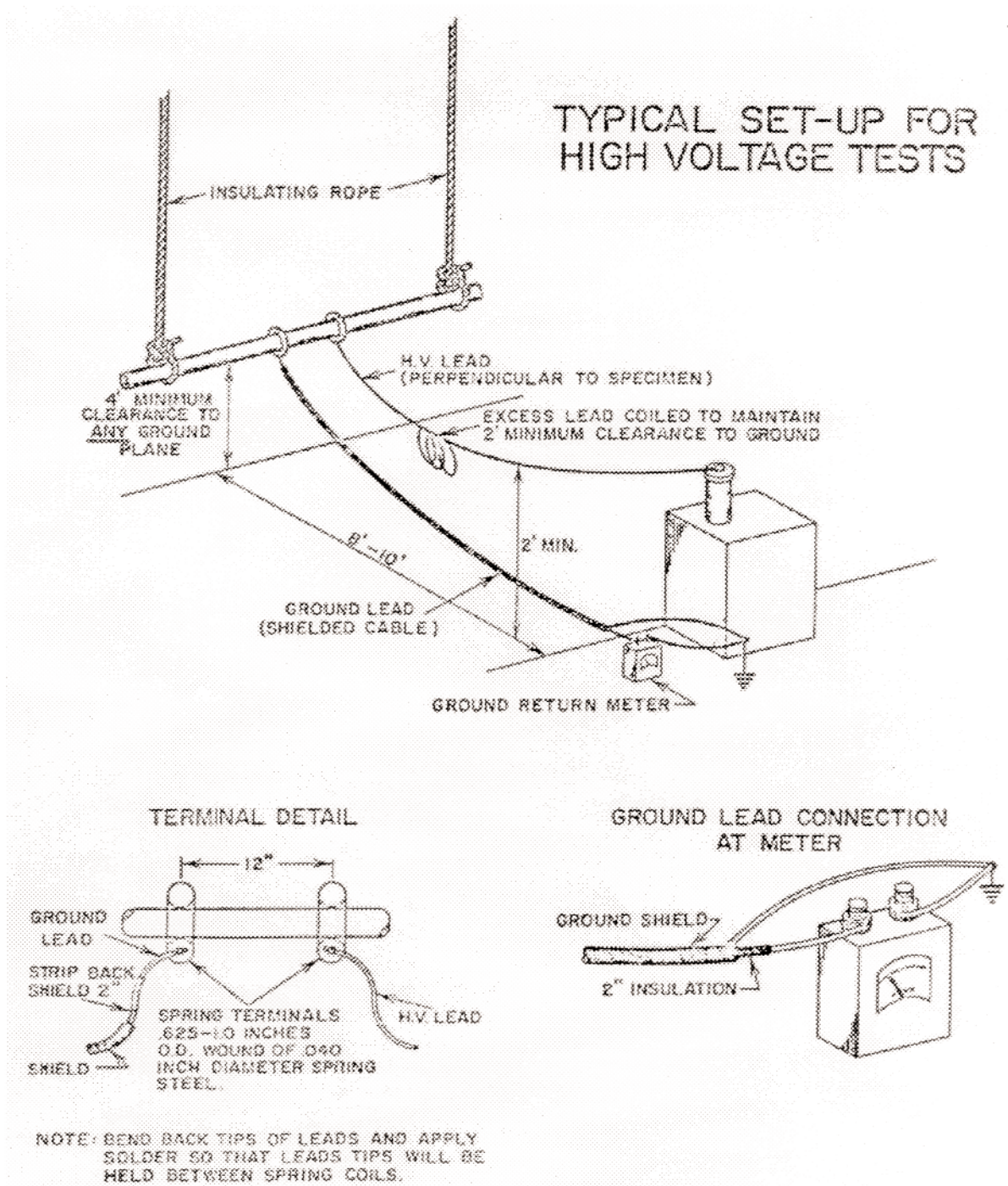

Results

Table 1:

Von DC Hi-Pot Test Dielectric Test Results		
Fiberglass Rod Sample	80 kV DC Dry	80 kV DC Wet
	Leakage Current (μA)	Leakage Current(μA)
Test (1)	2.5	10.5
Test (2)	9	11
Control (1)	12	19
Control (2)	7	10

Conclusion:

Under the foregoing test procedure, the Rainbow spray coating provided a dielectric finish equal to or better than the manufacturer's surface finish when properly cleaned. The wet leakage current values for both the control and test fiberglass rod samples fell well within the acceptable limits of $\leq 80 \mu\text{A}$ as set forth in the test procedure.

Approved:

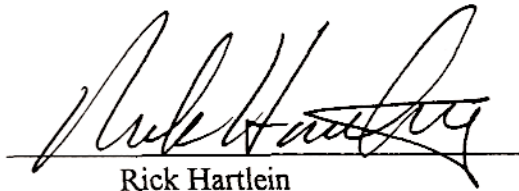

Rick Hartlein

JLR/

cc: Stan Harper (Manager NEETRAC)
Bob Boozer



Standard Specification for Fiberglass-Reinforced Plastic (FRP) Rod and Tube Used in Live Line Tools¹

This standard is issued under the fixed designation F 711; the number immediately following the designation indicates the year of original adoption or, in the case of revision, the year of last revision. A number in parentheses indicates the year of last reapproval. A superscript epsilon (ϵ) indicates an editorial change since the last revision or reapproval.

1. Scope

1.1 This specification applies to insulating foam-filled tubes and rods made from fiberglass-reinforced plastic (FRP) that are intended for use in live line tools.

1.2 This specification does not include insulating foam-filled tubes and rods from other materials. Specifications for fittings and attachments to foam-filled tubes and rods for complete tools are not covered in this specification.

1.3 This specification establishes the technical characteristics that the tubes and rods must satisfy.

1.4 The following safety hazards caveat pertains only to the test method portion, Section 13, of this specification. *This standard does not purport to address all of the safety problems, if any, associated with its use. It is the responsibility of the user of this standard to establish appropriate safety and health practices and determine the applicability of regulatory limitations prior to use.*

2. Referenced Documents

2.1 ASTM Standards:

D 149 Test Method for Dielectric Breakdown Voltage and Dielectric Strength of Solid Electrical Insulating Materials at Commercial Power Frequencies²

D 638 Test Method for Tensile Properties of Plastics³

D 695 Test Method for Compressive Properties of Rigid Plastics³

3. Terminology

3.1 Descriptions of Terms Specific to This Standard:

3.1.1 *acceptance test*—a type of test made at the option of the purchaser.

3.1.2 *design*—a type of test made on a sample treated as representative of an industrial product. These tests will not generally be repeated in quantity production.

3.1.3 *insulating tubes and rods*—fiberglass-reinforced plastic (FRP) products manufactured using processes so that the tubes and rods produced will meet the electrical and mechanical tests prescribed in this standard.

3.1.4 *interior foam-filled tube*—homogeneous unicellular thermosetting foam filling with closed cells blown with noncombustible gases. The foam filling shall be bonded to the interior tube wall. The foam filling should be free of

voids, separations, holes, cracks, etc.

3.1.5 *routine test*—a type of test made regularly on production material.

3.1.6 *visual inspection*—a visual check made to detect constructional defects.

4. Ordering Information

4.1 *Outside Diameter Sizes*—Foam-filled FRP tube and solid FRP rod shall meet the outside diameter dimensions shown in Table 1. The tolerances shown will assist in assuring interchangeability with interfacing equipment.

4.2 Inspection of the material shall be agreed upon between the purchaser and the seller as part of the purchase contract.

5. Materials and Manufacture

5.1 Except for those test methods leading to destruction, neither the FRP tube, foam, nor the bond between them shall deteriorate during the prescribed mechanical and electrical tests of this specification.

6. Physical Requirements

6.1 The materials shall conform to the diameters prescribed in Table 1 for tube and rod.

6.2 The standard sizes listed by nominal diameter are recommended and do not preclude the manufacture of other sizes or shapes.

7. Weight

7.1 It has not been found necessary to specify the weight of the product produced under this specification in order for it to comply with performance requirements.

8. Workmanship, Finish, and Appearance

8.1 The external surface shall be uniform, symmetrical,

TABLE 1 Standard Tube and Rod Outside Diameters

TYPE	Nominal Diameter		Min Diameter		Max Diameter	
	in.	(mm)	in.	(mm)	in.	(mm)
Tube	1	(25.4)	0.98	(24.9)	1.02	(25.9)
	1¼	(31.8)	1.22	(31.0)	1.27	(32.3)
	1½	(38.1)	1.47	(37.3)	1.53	(38.9)
	1¾	(44.5)	1.73	(43.9)	1.78	(45.2)
	2	(50.8)	1.97	(50.0)	2.04	(51.8)
	2½	(63.5)	2.47	(62.7)	2.54	(64.5)
	3	(76.2)	2.97	(75.3)	3.04	(77.2)
Rod	¾	(9.5)	0.369	(9.4)	0.385	(9.8)
	½	(12.7)	0.490	(12.4)	0.510	(13.0)
	⅜	(15.9)	0.610	(15.5)	0.635	(16.1)
	¼	(19.1)	0.720	(18.3)	0.765	(19.4)

¹ This specification is under the jurisdiction of ASTM Committee F-18 on Electrical Protective Equipment for Workers and is the direct responsibility of Subcommittee F18.20 on Tools.

Current edition approved Feb. 24, 1989. Published April 1989. Originally published as F 711 – 81. Last previous edition F 711 – 83.

² Annual Book of ASTM Standards, Vol 10.01.

³ Annual Book of ASTM Standards, Vol 08.01.

and free of abrasions, scratches, blemishes, and surface defects.

8.2 Any defect that may capture an impurity or impair the dielectric integrity of the product shall be cause for rejection.

8.3 FRP rod or tube material after which a finish coating, such as paint, is applied must meet all physical, electrical, and mechanical requirements.

9. Sampling

9.1 *Design Test*—Perform the test on a minimum of three samples.

9.1.1 The design test will be used to qualify a specific item and normally will not be repeated during production.

9.2 *Sample Test*—A test specimen shall consist of one or more items, dependent on 1 % of the lot being tested.

9.2.1 A lot is represented either by all items produced in one production run or in one shipment.

9.2.2 Lots of new, unused items shall have test specimens selected at random.

9.3 *Routine Test*—Perform the test on all pieces delivered to the purchaser.

9.4 *Acceptance Test*—A test made at the option of the purchaser.

10. Conduct of Tests on Samples

10.1 Mechanical:

Test	Type	Material
Fuchsine wicking	design	tube
Bending deflection	design	tube
Horizontal crush	acceptance	tube
	design	tube
Tension	design	rod
Shear	design	tube
Compression	design	tube
Modulus of elasticity (tension)	design	rod
Mechanical aging (flexure)	design	rod
	design	tube
Visual	design	rod
	acceptance	tube
Dimensional	acceptance	rod
	acceptance	tube
	acceptance	rod
	acceptance	tube
	acceptance	rod
	acceptance	tube

10.2 Electrical:

Test	Type	Material
Dielectric current (leakage) (before moisture conditioning)	design	rod
Dielectric current (leakage) (after moisture conditioning)	design	tube
Dielectric current (leakage) (after moisture conditioning)	design	rod
Dielectric current (leakage) (after moisture conditioning)	design	tube
Dielectric current (leakage) (after moisture conditioning)	routine	rod
Dielectric current (leakage) (after moisture conditioning)	routine	tube

11. Number of Tests and Retests

11.1 Tubes:

11.1.1 *Fuchsine Wicking Tests*—Three samples, each 1 . (25 mm) long.

11.1.2 *Bending Deflection Test*—One sample, 8 ft. 5 in. (2.6 m) or longer.

11.1.3 *Horizontal Crush Test*—One sample, three diameters long.

11.1.4 *Tension Test*—Three samples 12 in. (300 mm) long, prepared in accordance with Fig. 1 and Test Method D 638.

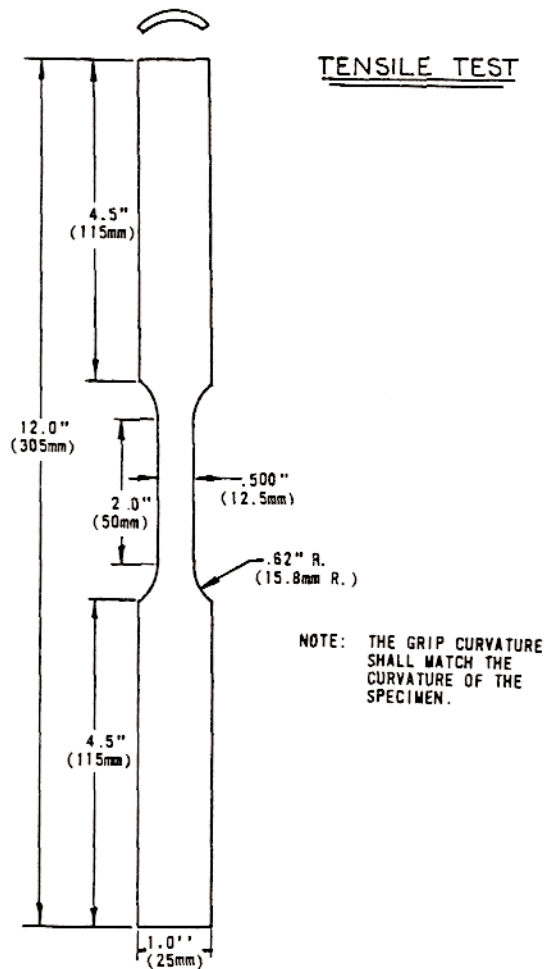

FIG. 1 Tension Test

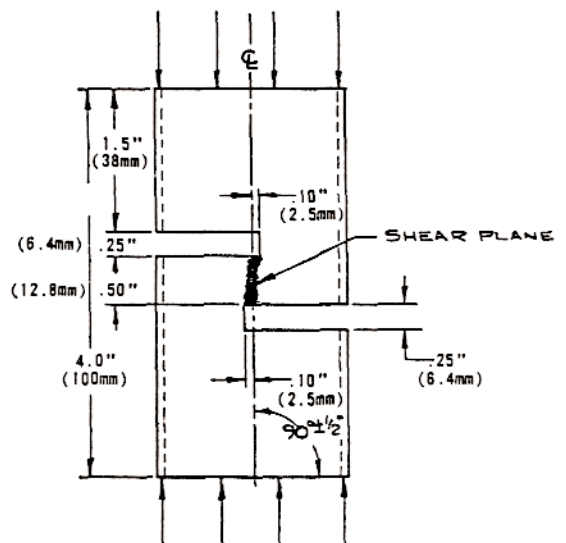

FIG. 2 Shear Test

11.1.5 *Shear Test*—Three samples, 4 in. (100 mm) long, prepared in accordance with Fig. 2.

11.1.6 *Electrical Tests*—Three samples, 12 in. (300 mm) long, prepared in accordance with Section 12.

11.2 *Rod:*

11.2.1 *Compression Test* (Applicable to solid rod only)—Three samples, 4 ft (1.2 m) long, prepared in accordance with Test Method D 695.

11.2.2 *Modulus of Elasticity (Tension)* (Applicable to solid rod only)—Three samples, 4 ft (1.2 m) long, prepared in accordance with Test Method D 638.

11.3 *Rod and Tube Mechanical Aging Tests:*

11.3.1 *Flexure*—Three samples of rod, 4 ft (1.2 m) or tube, 8 ft (2.4 m) in length.

12. Specimen Preparation

12.1 The sample for the dielectric test shall be 12 in. (9300 mm) in length.

12.2 *Conditioning Prior to Electrical Tests:*

12.2.1 Prior to the first or initial electrical test, the sample shall be cleaned with a suitable solvent, as recommended by the manufacturer (specifically a solvent that neither destroys the materials from which the tube or rod is made, nor leaves any residue on the surface of the sample).

12.2.2 All electrical (dielectric) tests (design) shall be made before and after exposure to humidity conditions, as specified, using 60-Hz voltage.

12.2.3 *Moisture Conditioning:*

12.2.3.1 *Before Current Measurement*—After initial cleaning (12.2.1), the sample shall remain in the ambient atmosphere of the test premises for at least 24 h.

12.2.3.2 Upon completion of the before-moisture conditioning electrical test (I_1), the sample shall then be placed in a suitable chamber and undergo the following conditioning prior to the after-moisture conditioning electrical test, (I_2).

Time:
Temperature:
Relative humidity:

168 h
 $23 \pm 2^\circ\text{C}$
93 %, or greater

13. Test Methods

13.1 *Visual Inspection*—Make a visual check to detect constructional defects (for example, evidence of faulty bonding between fibers and resin, air bubbles, foreign bodies, or particles).

13.2 *Electrical Tests*—The test apparatus shall be designed to provide the operator full protection in the performance of his duties and provide reliable means of de-energizing and grounding the high voltage circuit.

13.2.1 During the course of the testing, there shall be no sign of flashover or puncture on any of the samples.

13.2.2 The ambient temperature for the test location shall not be lower than 68°F (20°C).

13.3 *Electrical Design Test*—A typical test setup is shown in Fig. 3. Details are shown in Figs. 4 through 9. The measuring equipment should not be less than 6 ft (1.8 m) from the high-voltage electrode. Shield and ground the assembly of connection for the measuring equipment. Vertically mount the test specimen at least 3 ft (0.9 m) above the floor on an insulating support. Apply the voltage of 100 kV rms at 60 Hz between the electrodes, in accordance with Test Method D 149 at a maximum voltage rise of 3000 V/s. Measure the current passing over or through the test specimen in rms values by passing it through a known resistance.

13.3.1 The current I_1 is the maximum dielectric current measured with an alternating voltage of 100 kV rms 60 Hz applied between the electrodes for 1 min.

13.3.2 After moisture conditioning and a light wiping with a dry cloth, the current I_2 is measured under the same conditions as was I_1 .

13.3.3 Locate the specimen in the same relative position to earth; the high-potential end of the sample shall be the same for both tests.

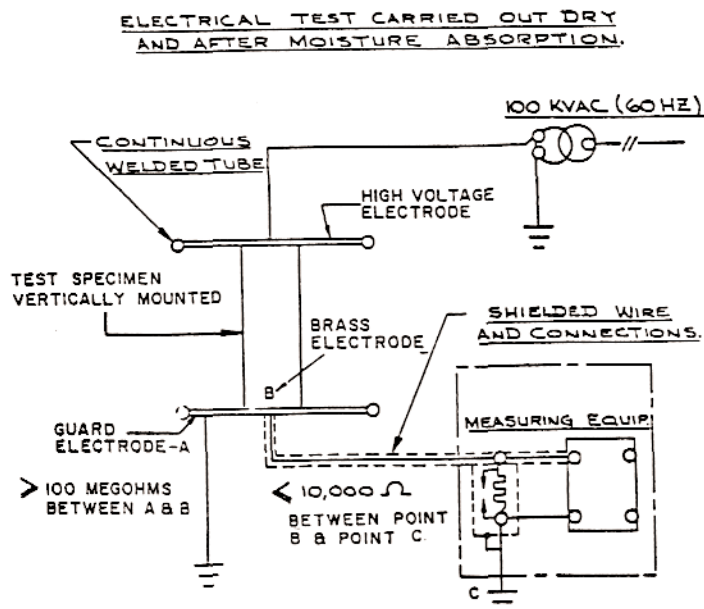

NOTE—For details of Fig. 3 see Figs. 4 through 9.

FIG. 3 Typical A-C Test Set Up

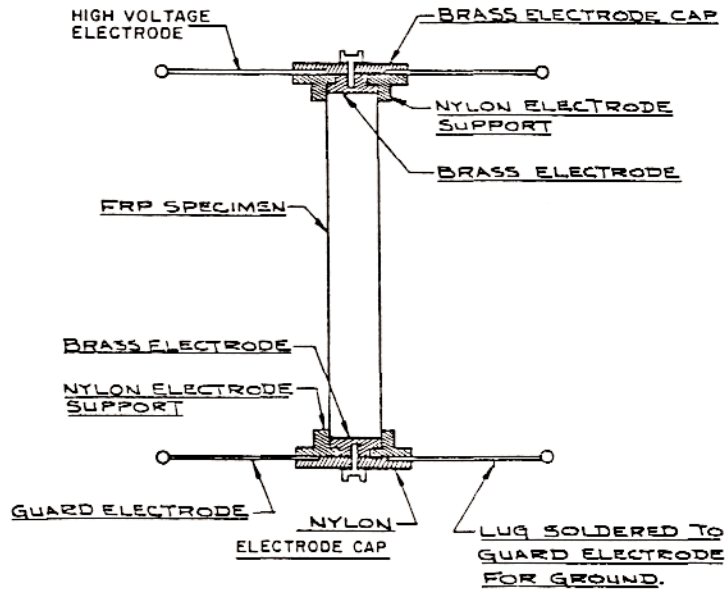

FIG. 4 Assembly Detail

13.3.4 *Test Results*—The currents (I_1) measured must be less than the values in Table 2. The difference between I_1 and I_2 shall be less than 20 μ A.

13.4 *Electrical Withstand Acceptance Test*—The typical test setup is shown in Fig. 10. Horizontally mount the test specimen at least 3 ft (0.9 m) above the floor on an insulating support. The electrodes shall be spaced 12 in. apart. An

alternative test method may be used upon agreement between manufacturer and purchaser. (See Appendix X1.)

13.4.1 During the electrical withstand acceptance test, the tubes or rods shall be subjected to an alternating voltage of 100 kV rms at power frequency in accordance with Test Method D 149 at a maximum voltage rise of 3000 V/s. The test voltage shall be applied between electrodes for 5 min.

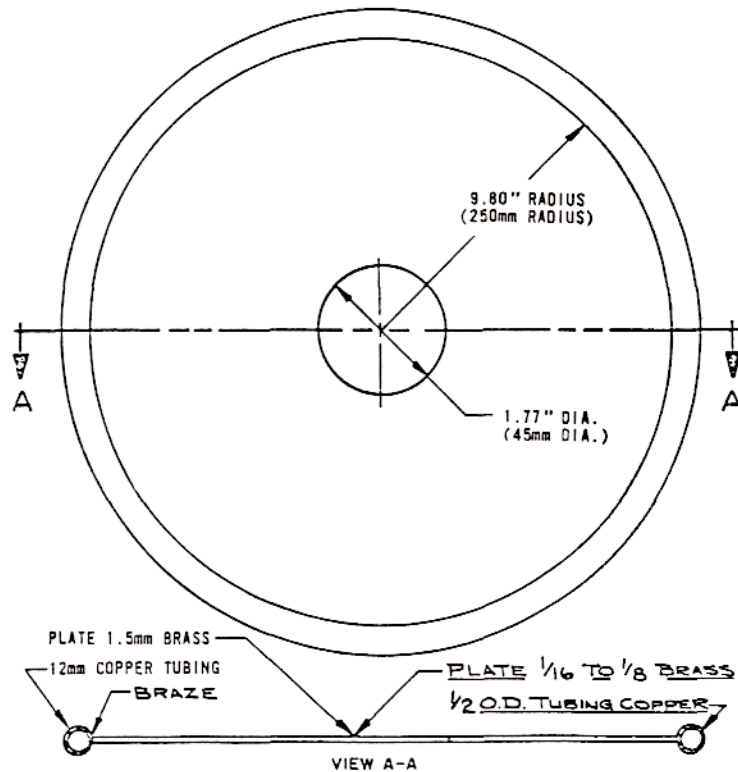

2 REQUIRED

FIG. 5 Electrode Detail

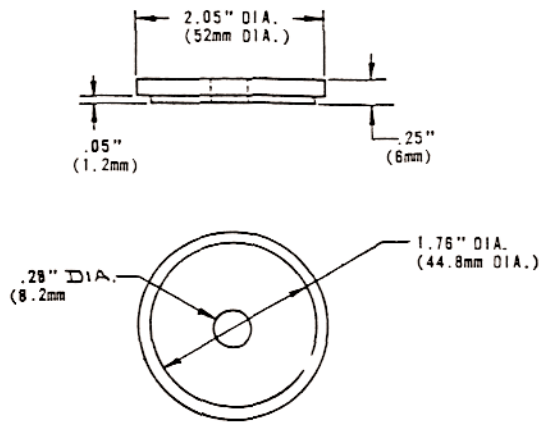

1 REQ'D NYLON
1 REQ'D BRASS

FIG. 6 Electrode Cap Detail

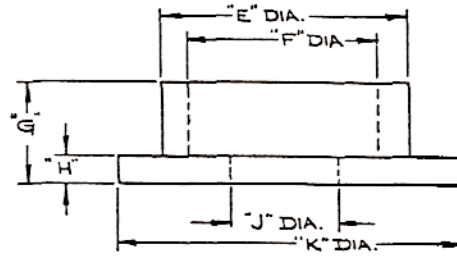

ROD (INCHES)							ROD (mm)						
DIA.	"E"	"F"	"G"	"H"	"J"	"K"	DIA.	"E"	"F"	"G"	"H"	"J"	"K"
3/8	.80	.41	.78	.20	.34	2.05	10	20	10.04	20	5	8.2	52
1/2	.90	.53	"	"	.40	"	15	25	15.04	20	5	8.2	52
5/8	1.10	.66	"	"	.52	"							
3/4	1.20	.79	"	"	.52	"							

TUBE (INCHES)							TUBE (mm)						
DIA.	"E"	"F"	"G"	"H"	"J"	"K"	DIA.	"E"	"F"	"G"	"H"	"J"	"K"
1	1.45	1.04	.78	.20	.52	2.05	32	42	32.2	20	5	22.2	52
1 1/4	1.70	1.29	"	"	"	"	39	49	39.2	20	5	29.2	52
1 1/2	1.95	1.55	"	"	"	"	51	61	51.2	20	5	37.2	61
1 3/4	2.20	1.80	"	"	"	"	64	74	64.2	20	5	37.2	74
2	2.45	2.06	"	"	"	2.45	77	87	77.2	20	5	37.2	87
2 1/2	2.95	2.55	"	"	"	2.95							
3	3.45	3.06	"	"	"	3.45							

2 REQ'D EACH SIZE
NYLON

FIG. 8 Nylon Electrode Support Detail

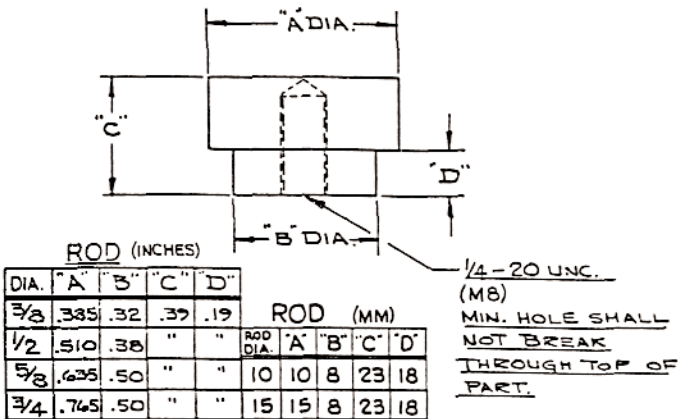

ROD (INCHES)					ROD (mm)				
DIA.	"A"	"B"	"C"	"D"	ROD DIA.	"A"	"B"	"C"	"D"
3/8	.385	.32	.39	.19					
1/2	.510	.38	"	"	10	10	8	23	18
5/8	.635	.50	"	"	15	15	8	23	18
3/4	.765	.50	"	"	15	15	8	23	18

TUBE (INCHES)					TUBE (mm)				
DIA.	"A"	"B"	"C"	"D"	TUBE DIA.	"A"	"B"	"C"	"D"
1	1.02	.50	.39	.19	32	32	22	10	4.9
1 1/4	1.27	"	"	"	39	39	29	10	4.9
1 1/2	1.53	"	"	"	51	51	37	10	4.9
1 3/4	1.78	"	"	"	64	64	37	10	4.9
2	2.04	"	"	"	77	77	37	10	4.9
2 1/2	2.53	"	"	"					
3	3.04	"	"	"					

2 REQ'D EACH SIZE
BRASS

FIG. 7 Brass Electrode Detail

13.4.2 During the course of the testing, there shall be no sign of flashover, puncture, tracking, or erosion on the surface of any sample. There shall be no perceptible temperature rise of any sample.

13.5 Mechanical Testing of FRP Tube:

13.5.1 Bending Deflection Test (design)—A tube 8 ft 5 in. (2.6 m) or longer shall be placed in a testing device such that

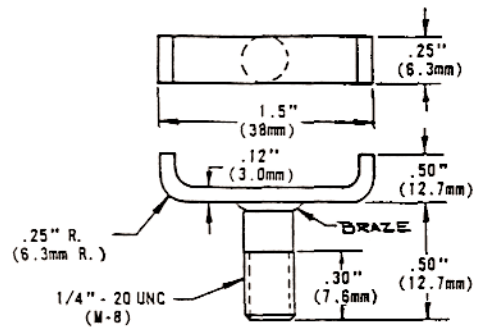

2 REQ'D BRASS

FIG. 9 Brass Screw Detail

the overhang arm is 60 in. (1.5 m) in length, and the distance between supports is as shown in Fig. 11.

13.5.1.1 The support shall be of the pole clamp-type (approximately 4 in. (100 mm) long) with the back clamp tightened to hold specimen in place while the front clamp remains loose and serves only as a fulcrum. Both clamps shall be free to pivot as load (in Table 3) is applied 60 in. (1.5 m) from center of front clamping device (see Fig. 11).

13.5.1.2 The deflection of each tube tested shall not exceed the value specified in Table 3.

TABLE 2 Flexure Forces and Leakage Current^A

TYPE	Outside Diameter		Flexure Forces		Leakage Current, I_1
	in.	(mm)	lbf	(N)	μA
Tube	1	(25.4)	220	(978.6)	5
	1¼	(31.8)	270	(1201.0)	6
	1½	(38.1)	370	(1645.8)	8
	1¾	(44.5)	550	(2446.5)	9
	2	(50.8)	670	(2980.3)	10
	2½	(63.5)	1680	(7473.0)	12
Rod	3	(76.2)	3030	(13 478.1)	14
	¾	(9.5)	50	(222.4)	6
	½	(12.7)	150	(667.2)	6
	⅝	(15.9)	375	(1668.0)	6
	¾	(19.1)	800	(3058.6)	6

^A Values listed for maximum I_1 are based on pole constructed of a relatively thin wall and filled internally with foam. Some special applications require a thicker wall, denser foam, or different materials, which could change the dielectric constant of the test setup and consequently I_1 . Tubes such as these will still meet the requirements of this standard if the dry leakage is less than twice the listed maximum value of I_1 in the table.

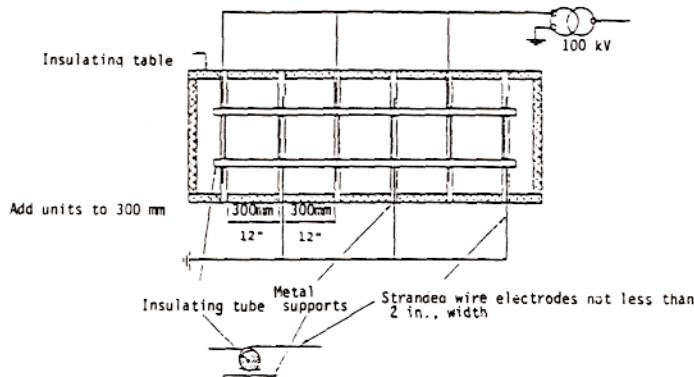

FIG. 10 Typical Test Arrangement for Electrical Withstand Acceptance Test

13.5.2 *Horizontal Crush Test (design)*—The test specimens shall be 3 nominal diameters in length. Each specimen shall be tested separately. Each specimen shall be placed between smooth, flat, parallel, and rigid plates for the test see Fig. 12). The length of the plates shall be at least equal to he specimen length plus ¼ in. (19 mm).

13.5.2.1 Reduce the distance between the two plates until a force, not greater than 20 lb, registers on the load nstrumentation. Zero all instrumentation.

13.5.2.2 The distance between the two plates is then continuously decreased at a constant rate between 0.08 to 0.2 in. (2 to 5 mm)/min. Once selected this constant rate shall not be changed for that test.

NOTE—It is recognized that horizontal crush tests performed at a higher constant displacement rate are more severe.

13.5.2.3 Record the constant displacement rate selected. Record the maximum force applied to the test specimen

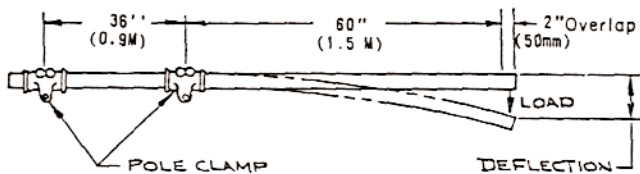

FIG. 11 Bending Deflection Test

TABLE 3 Deflection

Outside Diameter of Tube		Applied Force		Max Deflection	
in.	(mm)	lbf	(N)	in.	(mm)
1	(25.4)	20	(89.0)	20	(508.0)
1¼	(31.8)	50	(222.4)	20	(508.0)
1½	(38.1)	50	(222.4)	10	(254.0)
1¾	(44.5)	50	(222.4)	5.5	(139.7)
2	(50.8)	50	(222.4)	3.5	(88.9)
2½	(63.5)	50	(222.4)	1.75	(44.5)
3	(76.2)	150	(667.2)	2	(50.8)

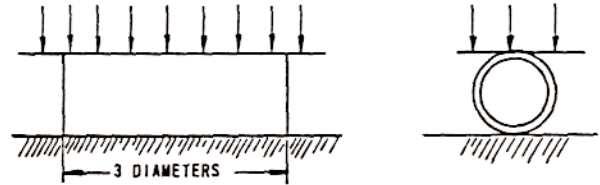

FIG. 12 Crush Test

during the first 0.25 in. (6 mm) displacement. All tubes shall be capable of exhibiting a crush strength equal to or in excess of minimum values listed in Table 4.

13.5.3 *Tension Test (design)*—The FRP tube shall exhibit axial tension strength equal to or in excess of the minimum values listed in Table 5. Cut the test specimens from the wall of a tube and accurately measure to permit cross section area calculations within 5 % of true value and in accordance with Test Method D 638 (see example in Fig. 1). The tensile strength of a tube is the product of the specimen ultimate load and the ratio of the area of the entire tube wall cross section to that of the test specimen. At the manufacturer's option the complete tube may be loaded to the tensile minimum of Table 5. The specimen length and holding means are optional with the manufacturer.

13.5.4 *Shear Test (design)*—FRP tube shall have a minimum average shear strength, parallel to the axis of the tube, as indicated in Table 6. Place the specimens between flat and

TABLE 4 Crush Minimums

Diameter		Min Crush Strength	
in.	(mm)	lbf	(N)
1	(25)	650	(2891)
1¼	(32)	750	(3336)
1½	(39)	800	(3559)
1¾	(44)	850	(3781)
2	(51)	890	(3959)
2½	(64)	1210	(5382)
3	(76)	1500	(6672)

TABLE 5 Tensile Minimums for FRP Tubes

Diameter		Min Tensile Strength	
in.	(mm)	lbf	(N)
1	(25.4)	14 000	(62 275.1)
1¼	(31.8)	18 000	(80 068.0)
1½	(38.1)	29 000	(12 8998.4)
1¾	(44.5)	42 000	(18 6825.3)
2	(50.8)	43 000	(19 1273.5)
2½	(63.5)	64 000	(28 4686.2)
3	(76.2)	99 000	(44 0374.0)

SUPPLEMENTARY REQUIREMENTS

The following supplementary requirement shall apply only when specified in the purchaser order.

S1. Acceptance

S1.1 At the option of the purchaser, all or any part of an order of tubes or rods may be subjected to the following checks:

- S1.1.1 Visual check for general appearance, surface blemishes, air bubbles, or foreign bodies,
- S1.1.2 Dimensional checks,

S1.1.3 *Electrical Tests*—Tubes or rods selected shall withstand 100 kV at 60 Hz/12 in. (300 mm) for 5 min with a maximum rise of 3000 V/s or 50 kV at 60 Hz over a minimum length of 6 in. (150 mm), and

S1.1.4 *Mechanical Tests*—Tubes selected for mechanical tests shall be subjected to the bending deflection test and the loading forces as prescribed in 13.3.1. Deflection shall not exceed values specified in Table 2.

APPENDIX

(Nonmandatory Information)

X1. Alternative Electrical Withstand Test

X1.1 The test apparatus shall be designed to provide the operator full protection in the performance of his duties and provide reliable means of de-energizing and grounding the high voltage circuit.

X1.2 The typical test set-up is shown in Figs. X1.1 and X1.2. The necessary equipment should be adequately shielded to provide accurate readings. The test fixture should be enclosed for worker protection and equipped with an exhaust fan to provide a stable atmosphere. A motor drive shall be utilized to ensure a uniform rate of feed. The feed rate should be proportional to the response time of the

metering circuit; that is, it should be run slow enough that maximum readings are obtained. At no time should this rate of feed exceed 40 ft/min.

X1.3 With 6 in. electrode spacing, the applied voltage will be 50 kV. The equipment shall be designed such that a flashover, excessive leakage current will disable the motor drive so that intentional action on the part of the operator is required to reset the equipment.

X1.4 Acceptable values of leakage current shall be a rise above ambient of less than I_1 as listed in Table 4.

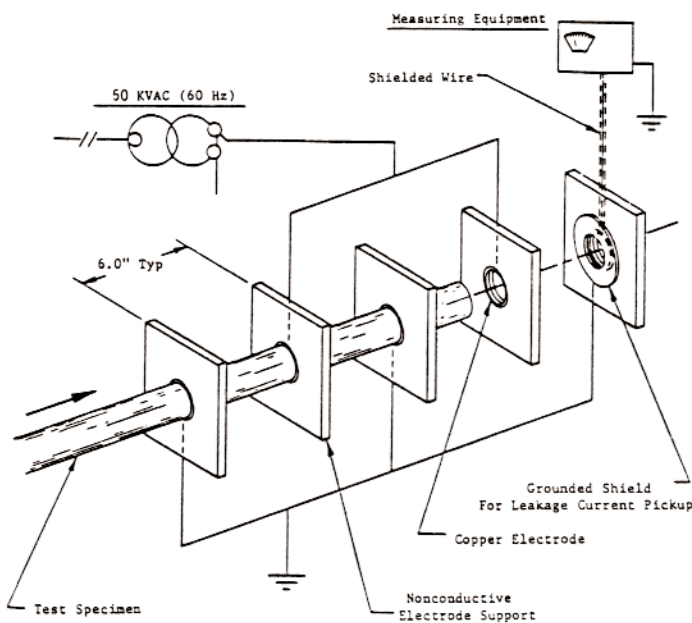

FIG. X1.1 Typical Test Set-Up

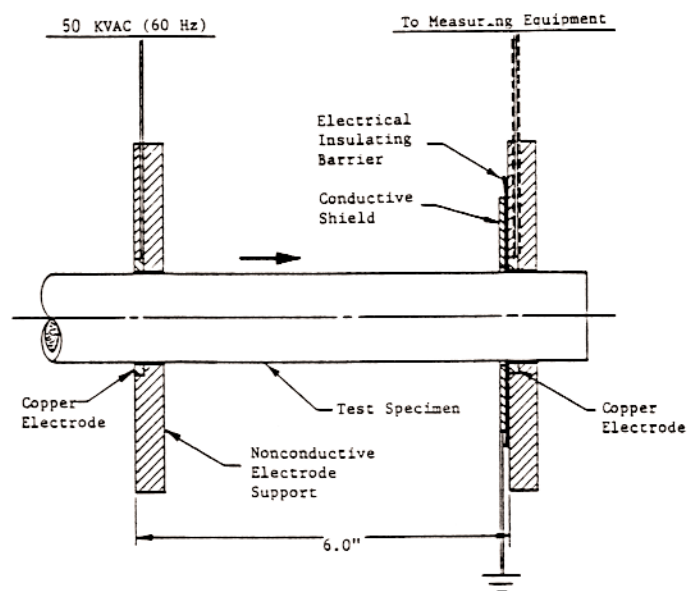

FIG. X1.2 Typical Test Set-Up

 F 711

The American Society for Testing and Materials takes no position respecting the validity of any patent rights asserted in connection with any item mentioned in this standard. Users of this standard are expressly advised that determination of the validity of any such patent rights, and the risk of infringement of such rights, are entirely their own responsibility.

This standard is subject to revision at any time by the responsible technical committee and must be reviewed every five years and if not revised, either reapproved or withdrawn. Your comments are invited either for revision of this standard or for additional standards and should be addressed to ASTM Headquarters. Your comments will receive careful consideration at a meeting of the responsible technical committee, which you may attend. If you feel that your comments have not received a fair hearing you should make your views known to the ASTM Committee on Standards, 1916 Race St., Philadelphia, PA 19103.



RAINBOW TECHNOLOGY
Specialists in Utility Chemicals & Safety Items

261 Cahaba Valley Parkway - Pelham, AL 35124-1146
Tel: 1.800.637.6047 / 205.733.0333
Fax: 1.800.521.6896 / 205.733.8930
www.rainbowtech.net
Woman-Owned Business Enterprise - Founded 1971

Safety Data Sheet (SDS)

Revised Date: October 6, 2015 **Preparation Date:** February 14, 2014

1 Identification of the substance and manufacturer

Customer	RAINBOW TECHNOLOGY CORPORATION	Distributed in Australia by
Product Name	Fiberglass Protective Coating	ADAPT AUSTRALIA
Product Number	4695	11-19 Global Drive
Manufacturer/Supplier	Rainbow Technology Corporation 261 Cahaba Valley Parkway Pelham, AL 35124 800.637.6047 www.rainbowtech.net	Westmeadows, Vic, Australia, 3049. PH: +61 3 9330 0666 Fax: +61 3 9330 0777
Contact Person	Larry Joe Steeley, Jr. 1-800-637-6047	Distributed in New Zealand by
Emergency Information	0800 764 766 in New Zealand 13 11 26 in Australia	ADAPT NEW ZEALAND 25 Hampden Street Picton 7220 Marlborough, New Zealand. PH: +64 2150 7831

2 Hazard(s) identification

GHS Hazard pictograms	 GHS02 GHS07 GHS08
Signal word	Danger
Hazard statements	Extremely flammable aerosol. Pressurized container: May burst if heated. Causes skin irritation. Causes serious eye irritation. Suspected of damaging fertility or the unborn child. May cause drowsiness or dizziness.
Precautionary statements	May cause damage to organs through prolonged or repeated exposure. If medical advice is needed, have product container or label at hand. Keep out of reach of children. Read label before use. Keep away from heat/sparks/open flames/hot surfaces. - No smoking. Pressurized container: Do not pierce or burn, even after use. IF IN EYES: Rinse cautiously with water for several minutes. Remove contact lenses, if present and easy to do. Continue rinsing. Store locked up. Protect from sunlight. Do not expose to temperatures exceeding 50 °C/122 °F. Dispose of contents/container in accordance with local/regional/national/international regulations.
HMIS-ratings (0 - 4):	Health= 1 Fire= 4 Physical Hazard= 3 PPE----B

3 Composition/information on ingredients

Chemical Description:		This product is a mixture of the substances listed below with nonhazardous additions.
Dangerous components:		
67-64-1	Acetone	22.36%
74-98-6	propane	15.68%
110-19-0	isobutyl acetate	14.13%
108-88-3	Toluene	13.54%
2807-30-9	Glycol Ether EP	10.26%
106-97-8	n-butane	9.21%
1330-20-7	xylene (mix)	1.82%

Safety Data Sheet (SDS)

4 First-aid measures

After eye contact: Move to fresh air. Rinse opened eye for several minutes under running water. If symptoms persist, consult a doctor.

After swallowing: Do not induce vomiting; immediately call for medical help. Rinse out mouth and then drink plenty of water.

5 Fire-fighting measures

Extinguishing agents: CO₂, extinguishing powder or water spray. Fight larger fires with water spray.

Special hazards: Can form explosive gas-air mixtures.

Protective equipment for firefighters: A respiratory protective device may be necessary.

Additional information: Cool endangered receptacles with water spray.

6 Accidental release measures

Personal precautions, protective equipment and emergency procedures: Use respiratory protective device against the effects of fumes/dust/aerosol.

Environmental precautions: Do not allow product to reach sewage systems or ground water.

Methods and material for containment and cleaning up: Dispose contaminated material as waste according to section 13.

7 Handling and storage

Precautions for safe handling: No special precautions are necessary if used correctly.

Fire/explosion protection: Pressurized container: protect from sunlight and do not expose to temperatures exceeding 50 °C, i.e. electric lights. Do not pierce or burn, even after use. Do not spray on a naked flame or any incandescent material. Do not smoke. Protect from electrostatic discharges.

Storage requirements: Observe pressurized container storage regulations. Consult with your local authorities.

8 Exposure controls/personal protection

Components with limit values that require monitoring at the workplace:

67-64-1 Acetone

PEL (USA)	Long-term value: 2400 mg/m ³ , 1000 ppm
REL (USA)	Long-term value: 590 mg/m ³ , 250 ppm
TLV (USA)	Short-term value: (1782) NIC-1187 mg/m ³ , (750) NIC-500 ppm
	Long-term value: (1188) NIC-594 mg/m ³ , (500) NIC-250 ppm
	BEI

74-98-6 propane

PEL (USA)	Long-term value: 1800 mg/m ³ , 1000 ppm
REL (USA)	Long-term value: 1800 mg/m ³ , 1000 ppm
TLV (USA)	refer to Appendix F

110-19-0 isobutyl acetate

PEL (USA)	Long-term value: 700 mg/m ³ , 150 ppm
REL (USA)	Long-term value: 700 mg/m ³ , 150 ppm
TLV (USA)	Long-term value: 713 mg/m ³ , 150 ppm

108-88-3 Toluene

PEL (USA)	Long-term value: 200 ppm
	Ceiling limit value: 300; 500* ppm
	*10-min peak per 8-hr shift
REL (USA)	Short-term value: 560 mg/m ³ , 150 ppm
	Long-term value: 375 mg/m ³ , 100 ppm
TLV (USA)	Long-term value: 75 mg/m ³ , 20 ppm
	BEI

106-97-8 n-butane

REL (USA)	Long-term value: 1900 mg/m ³ , 800 ppm
TLV (USA)	Short-term value: 2370 mg/m ³ , 1000 ppm

1330-20-7 xylene (mix)

PEL (USA)	Long-term value: 435 mg/m ³ , 100 ppm
REL (USA)	Short-term value: 655 mg/m ³ , 150 ppm
	Long-term value: 435 mg/m ³ , 100 ppm
TLV (USA)	Short-term value: 651 mg/m ³ , 150 ppm
	Long-term value: 434 mg/m ³ , 100 ppm
	BEI

Safety Data Sheet (SDS)

Ingredients with biological limit values:

67-64-1 Acetone

BEI (USA) 50 mg/L
 Medium: urine
 Time: end of shift
 Parameter: Acetone (nonspecific)

108-88-3 Toluene

BEI (USA) 0.02 mg/L
 Medium: blood
 Time: prior to last shift of workweek
 Parameter: Toluene

0.03 mg/L
 Medium: urine
 Time: end of shift
 Parameter: Toluene

0.3 mg/g creatinine
 Medium: urine
 Time: end of shift
 Parameter: o-Cresol with hydrolysis (background)

1330-20-7 xylene (mix)

BEI (USA) 1.5 g/g creatinine
 Medium: urine
 Time: end of shift
 Parameter: Methylhippuric acids

Hygienic protection: Immediately remove all soiled and contaminated clothing.
 Wash hands after use.
 Avoid contact with the eyes and skin.
 Do not eat or drink while working.

Breathing equipment: A respirator is generally not necessary when using this product outdoors or in large open areas. In cases where short and/or long term overexposure exists, a charcoal filter respirator should be worn. If you suspect overexposure conditions exist, please consult an authority on chemical hygiene.

Hand protection: Protective gloves. The glove material must be impermeable and resistant to the substance.

Eye protection: Tightly sealed goggles

9 Physical and chemical properties

Appearance: Aerosol.
Odor: Aromatic
Odor threshold: Not determined.
pH-value: Not determined.
Boiling point: -44 °C (-47 °F)
Flash point: -19 °C (-2 °F)
Flammability (solid, gaseous): Not applicable.
Decomposition temperature: Not determined.
Auto igniting: Product is not self-igniting.
Danger of explosion: In use, may form flammable/explosive vapour-air mixture.
Lower Explosion Limit: 1.7 Vol %
Upper Explosion Limit: 23.3 Vol %
Specific Gravity: Between 0.77 and 0.85 (Water equals 1.00)
Vapour density: Not determined.
Evaporation rate: Not applicable.
Partition coefficient (n-octanol/water): Not determined.
VOC content: 626.3 g/l / 5.23 lb/gl
VOC content (less exempt solvents): 65.1 %
MIR Value: 1.45
Solids content: 11.1 %
Other information: No further relevant information available.

10 Stability and reactivity

Conditions to avoid: Do not allow the can to exceed 120 degrees Fahrenheit. Stable at normal temperatures.
Possibility of hazardous reactions: No dangerous reactions known.
Hazardous decomposition: No dangerous decomposition products known.

Safety Data Sheet (SDS)

11 Toxicological information

Skin effects: No irritant effect.
Eye effects: Irritating effect.
Sensitization: No sensitizing effects known.

Carcinogenic categories

IARC (International Agency for Research on Cancer)

108-88-3	Toluene	3
1330-20-7	xylene (mix)	3

NTP (National Toxicology Program)

None of the ingredients is listed.

OSHA-Ca (Occupational Safety & Health Administration)

None of the ingredients is listed.

12 Ecological information

Aquatic toxicity: Hazardous for water, do not empty into drains.
Persistence and degradability: The product is degradable after prolonged exposure to natural weathering processes.
Bioaccumulative potential: No further relevant information available.
Mobility in soil: No further relevant information available.
Other adverse effects: No further relevant information available.

13 Disposal considerations

Dispose of in accordance with local, state, and federal regulations. Do not puncture, incinerate, or compact. Partially empty cans must be disposed of responsibly. Do not heat or cut empty containers with electric or gas torches.
Recommendation: Completely empty cans should be recycled.

14 Transport information

DOT, ADR N/A
UN proper shipping name:
DOT Aerosols, flammable
ADR 1950 Aerosols
IATA AEROSOLS, flammable
Transport hazard class(es):
Class 2.1
Special precautions for user: Warning: Gases
EMS Number: F-D,S-U
Quantity limitations On passenger aircraft/rail: 75 kg
 On cargo aircraft only: 150 kg

ADR
Excepted quantities (EQ) Code: E0
 Not permitted as Excepted Quantity

IMDG

Limited quantities (LQ) 1L
Excepted quantities (EQ) Code: E0
 Not permitted as Excepted Quantity

Packaging Group: --
UN "Model Regulation": UN1950, Aerosols, 2.1

15 Regulatory information

SARA Section 355 (extremely hazardous substances):

None of the ingredients in this product are listed.

SARA Section 313 (Specific toxic chemical listings):

108-88-3	Toluene
1330-20-7	xylene (mix)

CPSC: This product complies with 16 CFR 1303 and does not contain more than 90 ppm of lead.

California Proposition 65 chemicals known to cause cancer:

100-41-4 ethyl benzene

California Proposition 65 chemicals know to cause developmental toxicity:

WHMIS Symbols for Canada:

108-88-3 Toluene
 A - Compressed gas
 D2A - Very toxic material causing other toxic effects



Safety Data Sheet (SDS)

EPA:

67-64-1	Acetone	I
110-19-0	isobutyl acetate	D
108-88-3	Toluene	II
1330-20-7	xylene (mix)	I

ACGIH:

67-64-1	Acetone	A4
110-19-0	isobutyl acetate	A4
108-88-3	Toluene	A4
1330-20-7	xylene (mix)	A4

NIOSH:

The following substances are regulated in the United States with reference to occupational exposure limits:

16 Other information

Contact: Larry Joe Steeley, Jr. 1-800-637-6047

US4